

No. 617,573.

Patented Jan. 10, 1899.

E. HUGHES.  
TOOL HOLDER.

(Application filed Jan. 18, 1898.)

(No Model.)

Fig-1-

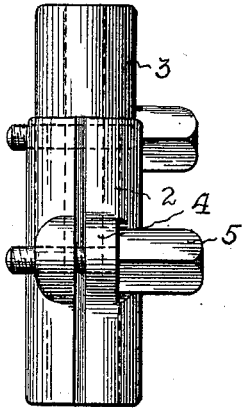

Fig-2-

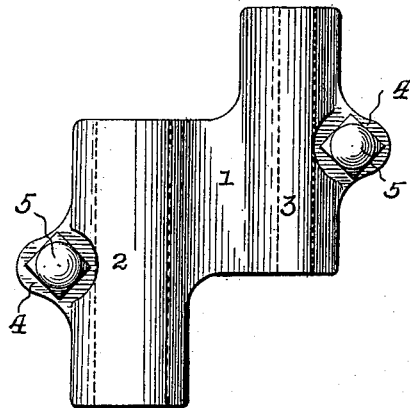

Fig-3-

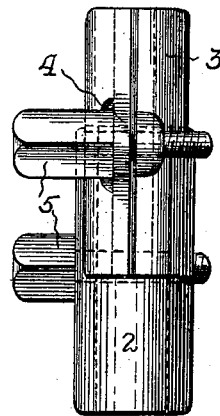

Fig-4-

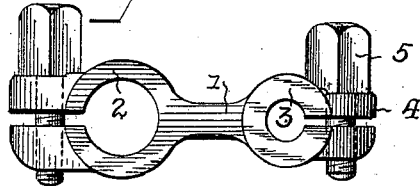
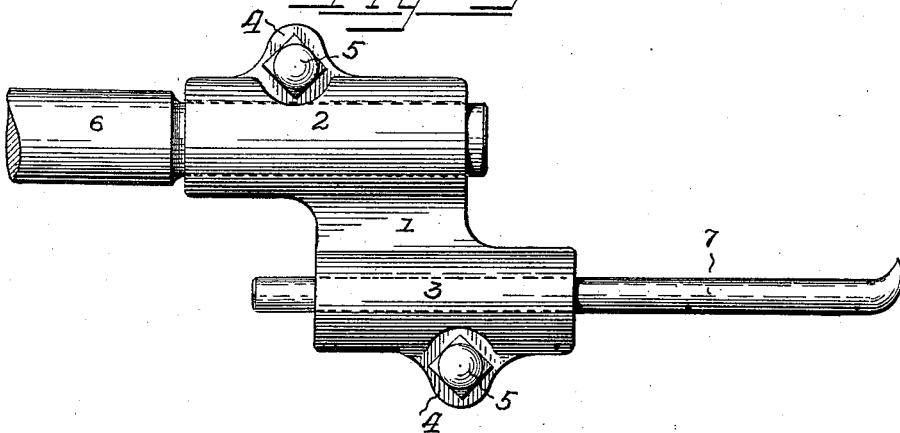

Fig-5-



Witnesses  
*C. Young.*  
*U. B. Hillyard.*

*Enoch Hughes* Inventor.

By *his* Attorneys,

*C. Snow & Co.*

# UNITED STATES PATENT OFFICE.

ENOCH HUGHES, OF AKRON, OHIO, ASSIGNOR OF ONE-HALF TO F. H. SMITH, OF SAME PLACE.

## TOOL-HOLDER.

SPECIFICATION forming part of Letters Patent No. 617,573, dated January 10, 1899.

Application filed January 18, 1898. Serial No. 667,109. (No model.)

*To all whom it may concern:*

Be it known that I, ENOCH HUGHES, a citizen of the United States, residing at Akron, in the county of Summit and State of Ohio, have invented a new and useful Tool-Holder, of which the following is a specification.

This invention relates to tool-holders which are principally designed for use in connection with lathe work, and has for its object to provide a holder of this character which can be used with drill-presses, shapers, and with boring and threading tools, one of the principal features residing in the special construction which admits of the tool being raised or lowered without disturbing its parallel relation with a given or normal position. When interchangeable heads or holders are provided, a boring-tool can be substituted for a threading-tool, and vice versa, without altering either the length of the tool or the stem in the post, and for heavy work the holders can be duplicated and placed upon opposite sides of the tool-post, so as to provide a double bearing for the tool.

For a full understanding of the merits and advantages of the invention reference is to be had to the accompanying drawings and the following description.

The improvement is susceptible of various changes in the form, proportion, and the minor details of construction without departing from the principle or sacrificing any of the advantages thereof, and to a full disclosure of the invention an adaptation thereof is shown in the accompanying drawings, in which—

Figure 1 is a front view of a tool-holder constructed in accordance with this invention. Fig. 2 is a side elevation. Fig. 3 is a rear view. Fig. 4 is an end view. Fig. 5 is a view in elevation showing the holder in operative relation.

Corresponding and like parts are referred to in the following description and indicated in the views of the drawings by the same reference characters.

The tool-holder consists of a body or stock 1 and clamps 2 and 3 at opposite ends thereof and in parallel relation. These clamps are

in the form of longitudinally-split sleeves, 50 having offstanding ears 4, which are apertured to receive clamp screws or bolts 5, by means of which the clamps are contracted, so as to grip the tool and the tool post or stem, as required. The clamps are of different diameters conformable to the size of the parts to be received therein and are somewhat longer than the body or stock to provide an extended frictional surface to insure a non-slipping of the holder upon the tool-post or the tool within the holder after the clamps have been properly adjusted to insure a binding of the parts gripped thereby. The clamps are extended at opposite ends, so as to lie in different transverse planes, thereby securing the best arrangement and enabling the holder to be positioned and manipulated more advantageously.

The tool-post or its stem is represented at 6 and the tool at 7, and these parts are inserted into the clamps from opposite ends, as clearly indicated in Fig. 5. If it be required to change the position of the tool so as to elevate or lower it, the clamp 2 is loosened and the holder is turned upon the part 6 until the tool is brought into the required position, when it is fixed by retightening the clamp 2 to cause it to grip the part 6 firmly. It will thus be seen that the tool can be changed without disturbing its parallelism to a normal or given position, which is of advantage in lathe and other work.

Having thus described the invention, what is claimed as new, and desired to be secured by Letters Patent, is—

1. A tool-holder comprising a body having a pair of oppositely-disposed clamp-sleeves arranged longitudinally in parallel planes, and transversely in different planes, and a separate clamping device for each sleeve, whereby each sleeve may be clamped and unclamped independently of the other, substantially as set forth.

2. A tool-holder comprising a body having formed integral therewith a pair of oppositely-disposed longitudinally-split clamp-sleeves arranged longitudinally in parallel planes, and transversely in different planes, each

sleeve being provided intermediate its ends  
and at its edges with offset parallel ears, and  
clamping - screws engaging the ears of the  
sleeves whereby each sleeve may be clamped  
5 and unclamped independently of the other,  
substantially as set forth.

In testimony that I claim the foregoing as

my own I have hereto affixed my signature in  
the presence of two witnesses.

ENOCH HUGHES.

Witnesses:

FRANCIS H. SMITH,  
H. E. CONNER.